

SPECIFIC ASPECTS IN POSITIONING OF THE RE/HEATING FURNACES AT A LAYOUT OF THE MODERN ROLLING MILLS

Omer Beganović

**University of Zenica, Institute „Kemal Kapetanović“ u Zenici
Zenica**

Faik Uzunović

**University of Zenica, Faculty of Metallurgy and Technology
Zenica**

Key words: re/heating furnaces, rolling mills layout, modern rolling mills

ABSTRACT

Some specific aspects in positioning of the re/heating furnaces at a layout of the modern rolling mills are presented in this paper. Theoretical and practical solutions in the above mentioned (further a.m.) field are presented for both, wire rod and light section bar mills. Some of the a.m. aspects are explained, confirming that even unexpected solution, from the theoretical point of view, could be successful and justified in practice, especially if some improvements are needed to be carried out on an existing layout of the concerned rolling mill, or in a vicinity of the other vital facilities on that rolling mill, or on the neighboring facilities.

INTRODUCTION

In a layout of any modern (hot) rolling mill there is a necessity to position one or more re-heating furnace/s, to be in an optimal position regarding the other main and auxiliary modern rolling mill equipment. In this paper it is presented an overview of the above mentioned (further a.m.) positioning, with a view to the theoretical approach and with some explanations from a practice, related to the IRON AND STEEL WORKS – ZENICA (now ARCELORMITTAL-Zenica). Regarding the theoretical considerations of the a.m. positioning which are presented, as well as from the practical point of view, some explanations are given, regarding specific requirements in a practice, from both technological and economic aspects. These specific requirements confirm that some practical solutions can be economically justified, although they are not in a compliance with theoretically technological recommendations.

1. THEORETICAL CONSIDERATIONS IN A POSITIONING OF THE RE-HEATING FURNACES AT MODERN ROLLING MILLS

General recommendations for the positioning of the re/heating furnace/s in modern rolling mills (for wire rod and light section bar mills) layout are [1,2,3,4,5,6,7,8]):

- Proximity to the roll stand/s
- One way of product travel

- Under a crane
- In a compliance with the other auxiliary equipment
- Enough space for the concerned workers in control, maintenance and repair works

1.1. Modern wire rod rolling mills case - 1

Theoretical example of modern wire rod (one-a, two-b, three-c and four-d strands) continuous rolling mill layout is presented at the Fig. 1.

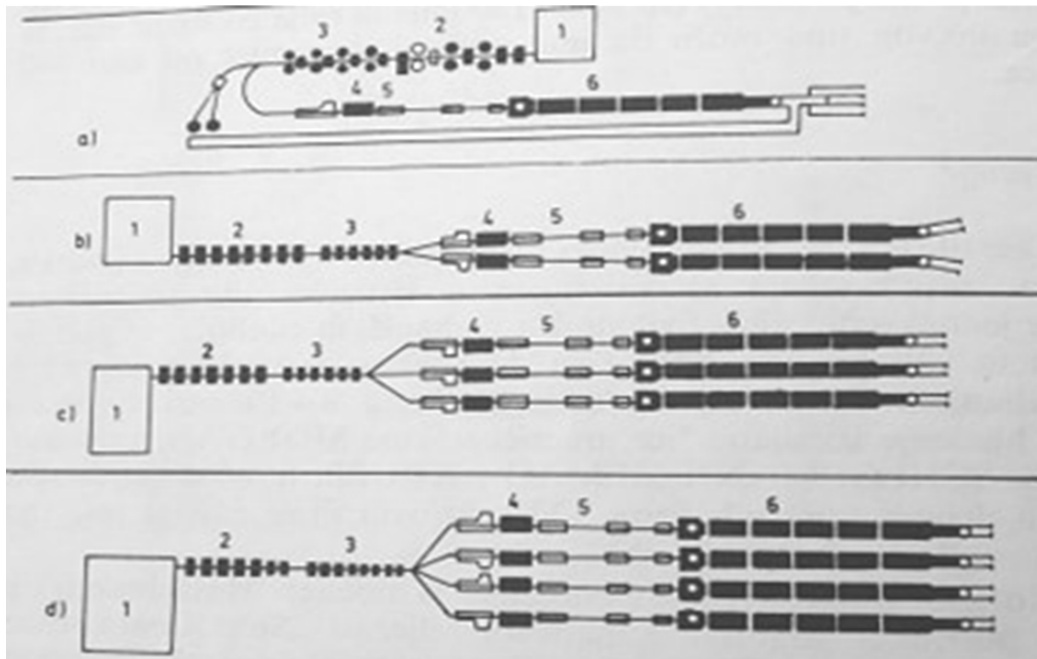

Figure 1. A layout of a modern generation - wire rod rolling mill [4]

It is clear from Fig. 1, that a walking beam type re/heating furnace (under symbol 1) is in an optimal position, because the exit of the billets (from sq. 80-150 mm) from that furnace is in the line of rolling, but on top of it, it gives supreme opportunity that the first part of the billet is already in rolling process, until the remaining part is still in the furnace (since there is one way product travel).

Nowadays there are no modern wire rod mill which is not in the compliance with the a.m. recommendations regarding re/heating furnace positioning in a layout of modern a.m. mill. Additionally in these mills, finishing group of roll stands is substituted by mono-bloc, with 10 W-carbide rolls/roll-rings in mutual alternative position of 90 degrees, to avoid twisting of rolled piece (so called NO TWIST FINISHING MILL – MONO-BLOC)

Further development of the a.m. mills goes toward higher rolling speed (above 100-150 m/s), better thermo-mechanical treatment-further TMT (STELMOR, or a similar one) and general computer control systems, from a re-heating furnace to a delivery conveyer.

1.2. Modern light section-bar rolling mills case - 2

Theoretical example of modern light section-bar two strands continuous rolling mill layout is presented at the Fig. 2.

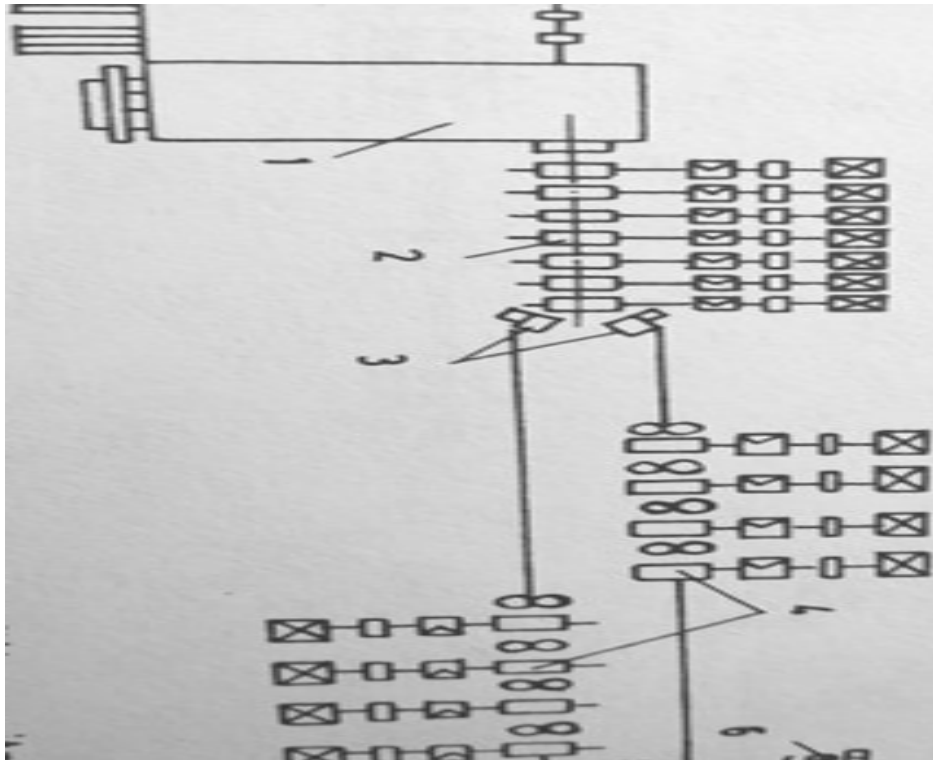

Figure 2. A layout of a modern generation of light section-bar rolling mill [5]

It is clear from Fig. 2 that a walking beam type re/heating furnace (under symbol 1) is in an optimal position, because the exit of the billets from that furnace is in the line of rolling, but on top of it, it gives supreme opportunity that the first part of the billet is already in rolling process, until the remaining part is still in the furnace (since there is one way of product travel), like it is the case – 1, with a modern wire rod mill.

Besides some technological news described in the heading 1.1. regarding a modern wire rod mill - case 1, there are a lot of similarities (starting with the positioning of a re/heating furnace) at a modern light section-bar mill (only there are no MONO-BLOCS, than the finishing mills, consisted of two high roll stands with the alternative rolls positioning horizontal-vertical) mostly used TMT is TEMPCORE.

Anyhow, that positioning of a furnace is the optimal one, and further development will go for a better computer control systems, from a re/heating furnace and TMT to a delivery coiler & conveyer or a cooling bed, and for an increase of rolling speed (20-30 m/s).

2. PRACTICAL CONSIDERATIONS IN A POSITIONING OF THE RE/HEATING FURNACES AT MODERN ROLLING MILLS

2.1. Modern wire rod rolling mills case - 3

The example of that Wire rod (two strands) continuous rolling mill layout is presented at the Fig. 3.

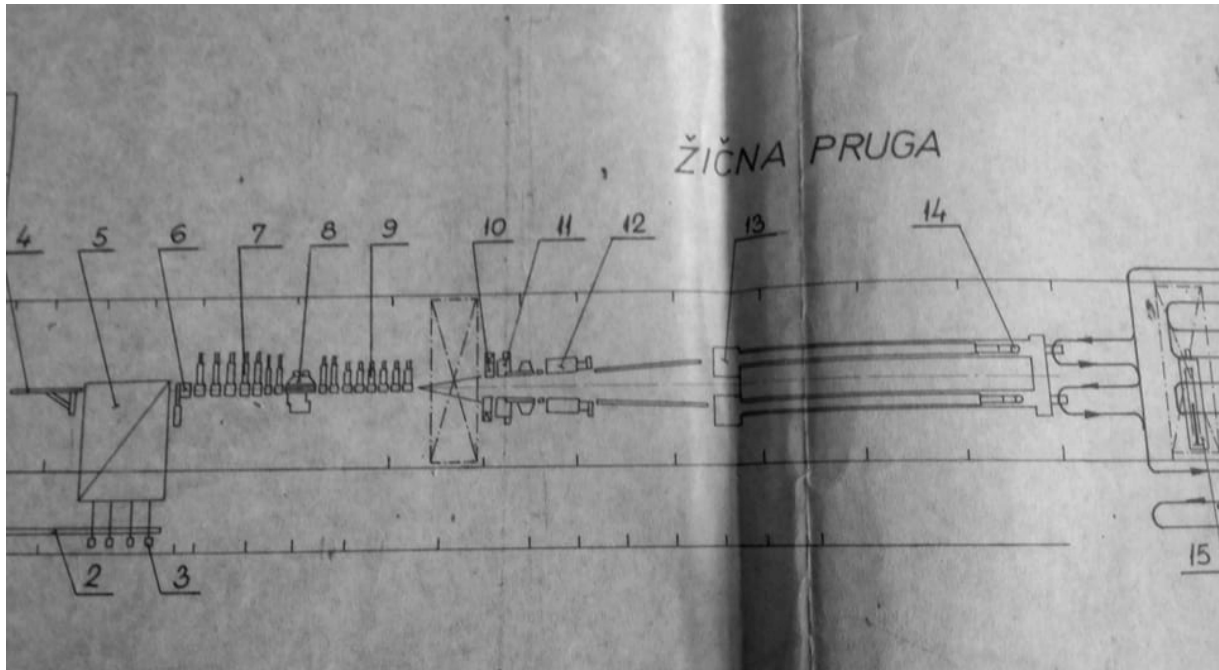

Figure 3. The layout of modern wire rod rolling mill in the IRON AND STEEL WORKS – ZENICA (built in 1977 technologically belonging to 1970-ies [2])

Third generation wire rod rolling mill in the IRON AND STEEL WORKS – ZENICA was built in 1977, technologically belonging to 1970-ies. Since it is the type of fully mechanized, digitalized and automated wire rod continuous rolling mill consisted of one rougher and one intermediate group of roll stands, with two finishing mills, each one consisted of MORGAN type mono-bloc, having ten two high stands, with alternatively horizontal-wise position of 45 and 135 degrees of W-carbide rolls-roll/rings. Such a modern, high capacity rolling mill has the only one walking beam type re/heating furnace (having capacity of 100 t/h), and that is under the symbol 5 at the a.m. Fig. 3.

It is important to notice that the exit of the billets from that furnace is in the line of rolling, but on top of it, it gives supreme opportunity that the first part of the billet is already in rolling process, until the remaining part is still in the furnace. Accordingly that is a big technical advantage, classifying (along with the other characteristics) that wire rod rolling mill as a sort of modern wire rod rolling mill design.

The layout presented at Figure 3 even was not changed later, due to some larger conception considerations concerned with production process at continuous casting (CC) unit, which was later unified for the billets of sq. 120 mm (instead of sq. 115 mm, which was rolled at Continuous billet mill, from CC blooms 320x280 mm), which was used, when that rolling mill was built and commissioned (accordingly the roll pass design was carried out starting from sq. 115 mm), but that is not considered in this paper.

That sort of the layout can be considered as the supreme one, and technologically is not changed till nowadays. Only computer control systems on the re/heating furnaces will be improved and the rolling speed increased (now is about 50-55 m/s, until the most modern wire rod mills achieve already 150 m/s).

2.2. Modern light section rolling mills case - 4

The example of that Light section-bar (two strands) continuous rolling mill layout in the IRON AND STEEL WORKS – ZENICA is presented at the Fig. 4.

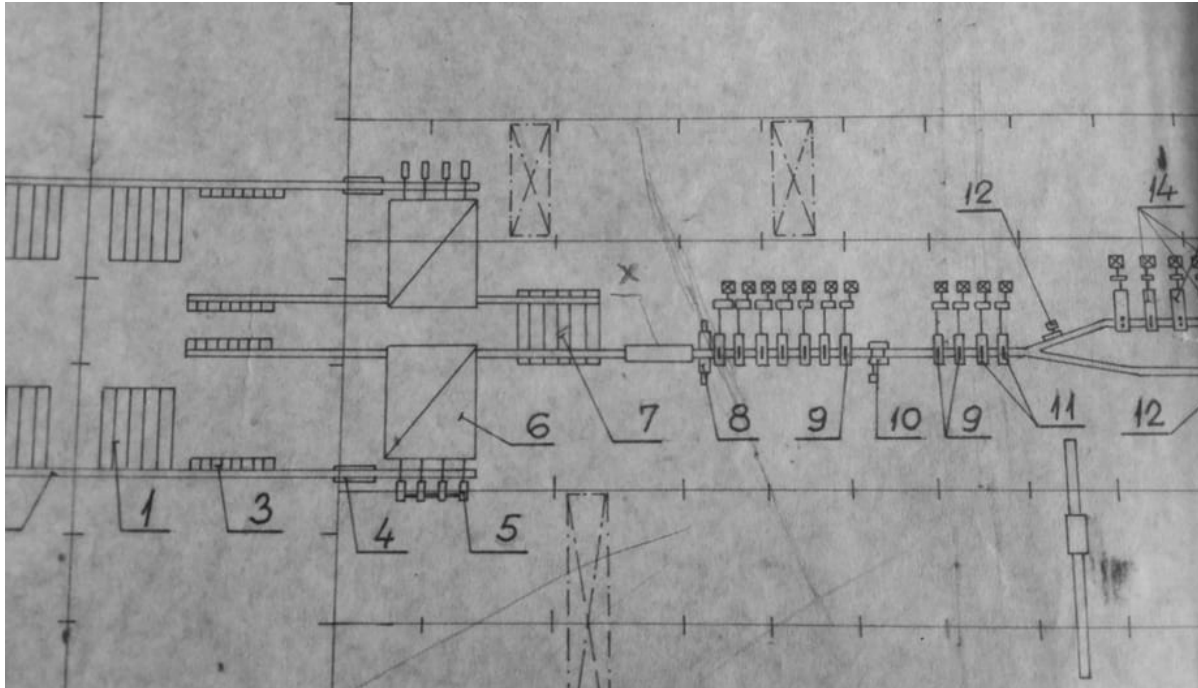

Figure 4. The layout of the third generation light section rolling mill in the IRON AND STEEL WORKS – ZENICA (built in 1977 technologically belonging to 1970-ies [2])

Modern light section-bar rolling mill in the IRON AND STEEL WORKS – ZENICA was built in 1977, technologically belonging to 1970-ies. Since it is the type of fully mechanized, digitalized and automated light section continuous rolling mill consisted of one rougher and one intermediate group of roll stands, with two finishing mills, each one consisted of six two high stands, with alternatively horizontal-vertical position of the rolls. Such a modern, high capacity rolling mill had two (same) walking beam type re/heating furnaces (each one having capacity of 80 t/h), and they are under the symbol 6 at the a.m. Fig. 4.

It is important to notice that the exit of the billets from one of the furnaces was not in the line of rolling, and one additional drag-over was installed there. Accordingly that was a sort of small technical inconvenience, without serious technological disturbance, although it is a sort of modern light section rolling mill design.

The layout presented at Fig. 4 was later changed, due to some larger conception considerations concerned with production process at continuous casting (CC) unit, which was later unified for the billets of sq. 120 mm (instead of sq. 80 mm, which was rolled at Continuous billet mill, from CC blooms 320x280 mm), which was used, when that rolling mill was built and commissioned. Accordingly the roll pass design was carried out starting from sq. 80 mm. That is why new owner, after the unification of sq. 120 mm billets at new radial CC machine, decided to do a reconstruction of that rolling mill (Light Section Rolling Mill – Sitna pruga) in 2004/5, and it is presented at the next page, at Fig. 5.

Light Section Rolling Mill

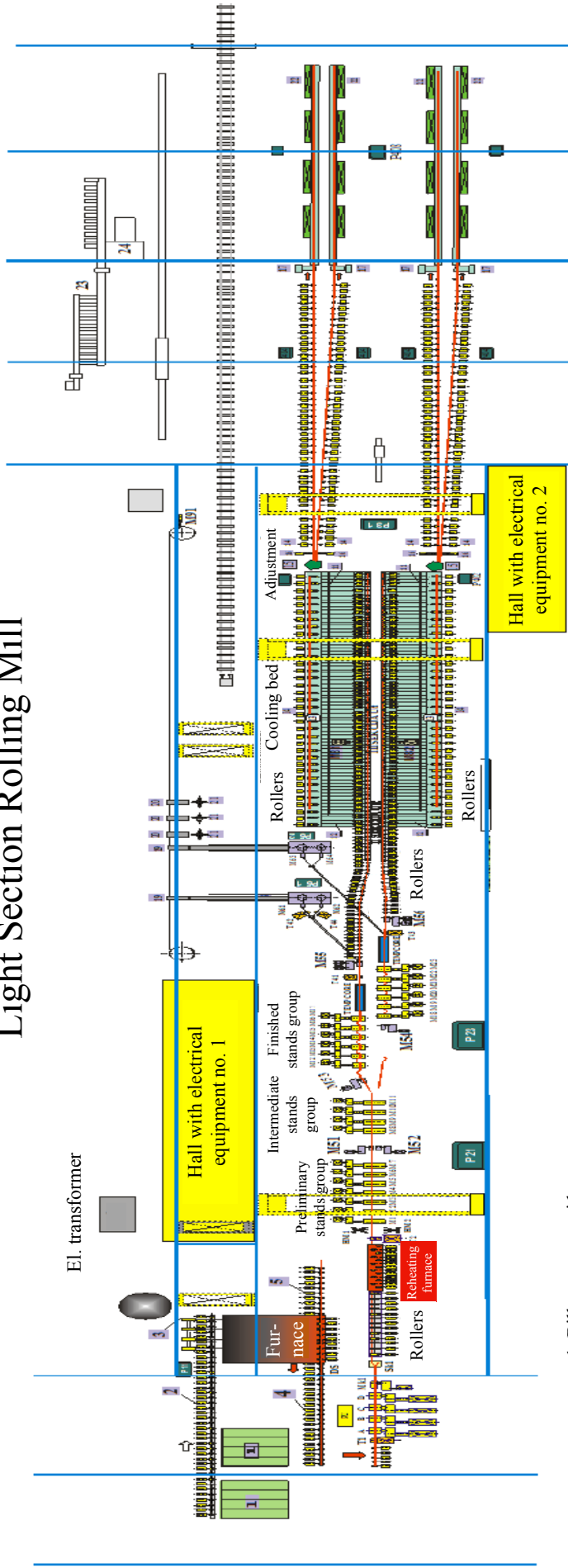

- 1 Billet storage grid
- 2 Inlet rollers
- 3 Pusher
- 4 Walkout rollers
- 5 Reverse rollers

Figure 5. The layout of modern and reconstructed light section-bar rolling mill in the former IRON AND STEEL WORKS – ZENICA [2]

That reconstruction was concerned primarily with the furnace and rougher area, which was relatively narrow. Instead of two existing re/heating furnaces, which were dismantled, the new one, having capacity of 120 t/h, of course again walking beam type, was built, at the place of the first one. Due to narrow area, at the place of the second one, new pre-rougher group of four roll stands was built (alternatively two horizontal and two vertical), to reduce sq. 120 mm to sq. 80 mm in these four passes, since the roll pass design for that rolling mill was carried out starting from the billets sq. 80 mm .

Such a big reconstruction in a narrow area had one inconvenient detail. After the exit from that newly built furnace, hot billets of sq. 120 mm, had to go the opposite way to the product travel, because of necessary reduction from sq. 120 to 80 mm. That would cause another technological problem (relatively quick cooling of a rolled billet), and another small tunnel type furnace was built, for an additional heating.

These were big and costly reconstruction works, and that time off was (also) used to improve computer control system at the existing rolling mill.

Finally it has remained modern light section-bar mill, but with the inconvenient product travel, as well as with the additional tunnel type furnace.

The owner considers that inconvenient rolling mill layout is still successful, since it enables to roll the unified sq. 120 mm billets for both Light section-bar mill and Wire rod mill, which is obvious technological advantage. That new layout is presented on Figure 5. It is a modern rolling mill, with a specific layout concerned with a re/heating furnace area within it, although the concept of that general reconstruction (CC machine and the Light section-bar mill) could be the matter of serious consideration, but is not a topic of this paper.

3. CONCLUSIONS

It is important to highlight that on modern rolling mills, of this group, the exit of the billets from the furnaces is in the line of rolling, but on top of it, described positioning of the re/heating furnace, like in the cases 1, 2 and 3, gives the supreme opportunity that the first part of the billet is already in rolling process (even rolled at the modern wire rod mills), until the remaining part is still in the furnace.

Theoretical considerations in positioning of the re/heating furnaces at modern rolling mills are generally used, but in some reconstructions, especially if narrow space is main limit, some unexpected solution could occur, even if they are not in the compliance with the a.m. technical considerations.

Such an example, especially regarding the layout and the furnace positioning, is presented regarding the reconstruction of the Light section-bar mil, presented at the Figure 5.

4. REFERENCE

- [1] IRON AND STEEL WORKS ZE NICA's Rolling Mills Division Documentation, 1954-2005.
- [2] Winterkamp H, Rimhland W, Design and Conception of Modern Merchant Mills, Iron and Steel Engineer, Sept. 1973.
- [3] Bene dict R. E, South Works' New Generation Rod Mill, Iron and Steel Engineer Year Book, 1978.
- [4] Causevic M. Working of Metals, Veselin Maslesa, Sarajevo, 1983.

- [5] The Making Shaping and Treating of Steel, 10th Edition, Association of Iron and Steel Engineers, USS, 1985.
- [6] Uzunovic F, CAD/CAM in Steel Rolling, Faculty of Metallurgy and Materials, Zenica, 2005.
- [7] Peter M, Barrie J, Industrial and Process Furnaces, 2nd Edition, Elsevier, 2014.
- [8] Clive D. Finniston H. M, Hopkins D. W, Calculation inFurnace Technology, Pergamon Press, 2nd Edition, 2016